

Outline Dimension:

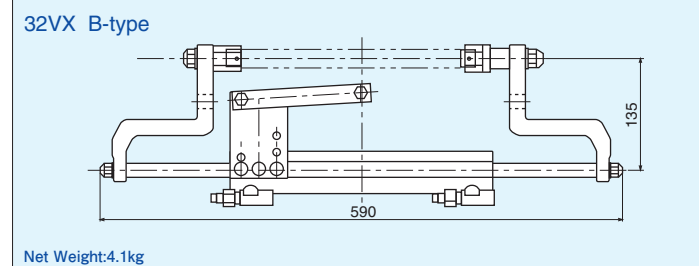

Oil-Water Separator UF-10K

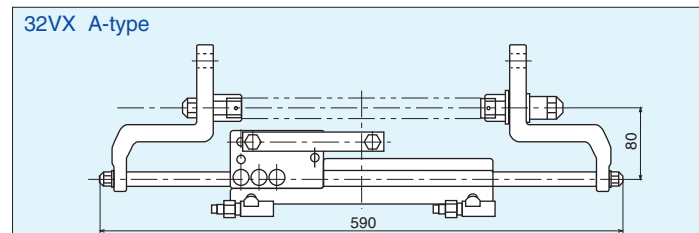
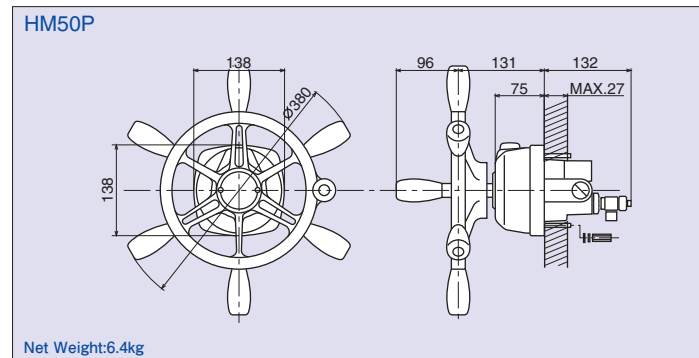
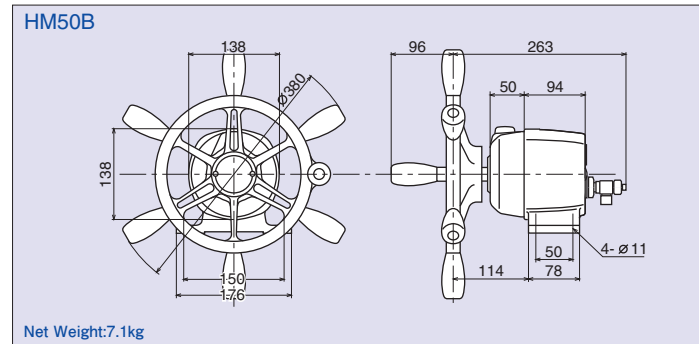
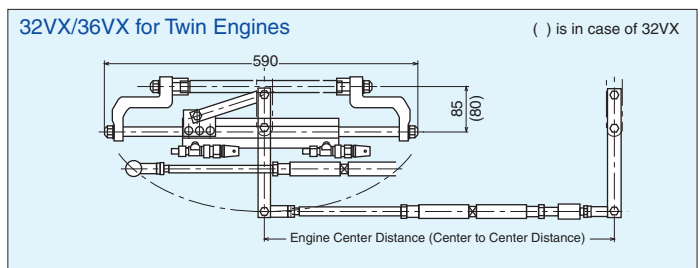
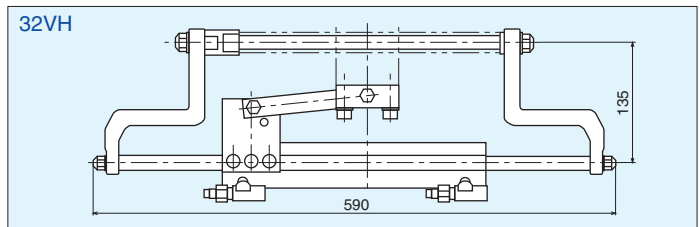
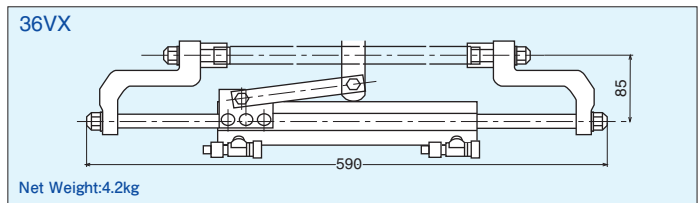
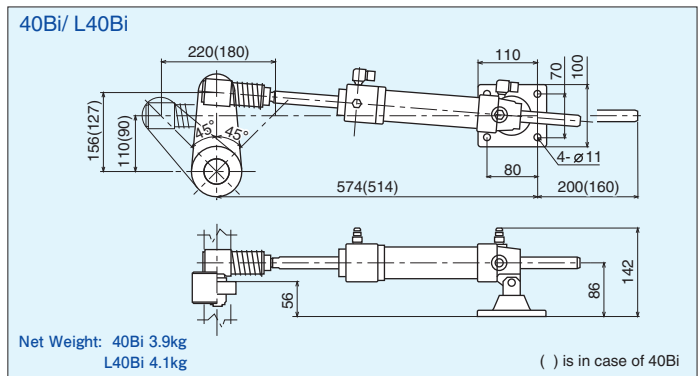
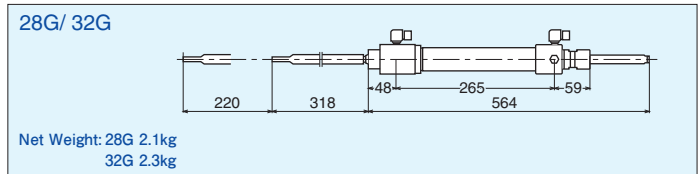
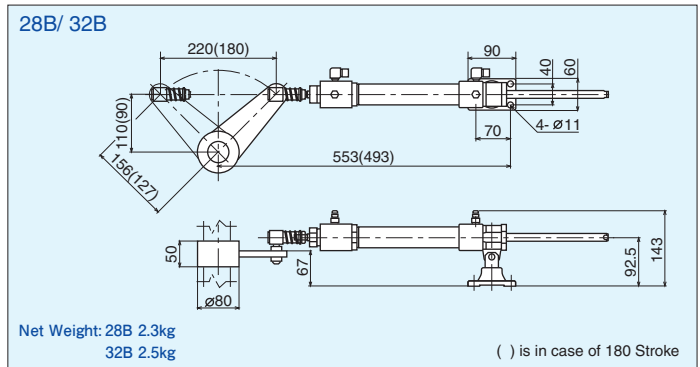

HAND HYDRAULIC STEERING SYSTEM

MHS Series



- MHS-30VXII
- MHS-32VX
- MHS-32VH
- MHS-36VX
- MHS-28G·B
- MHS-32G·B
- MHS-32UB
- MHS-40Bi
- MHS-L40Bi



UNIKAS INDUSTRIAL INC.

HQ & Factory : 455 Nishibara, Nagi-cho, Katsuta-gun, Okayama, 708-1306 Japan
TEL : +81 (0)868 36 3131 FAX : +81 (0)868 36 6209

Osaka Operation : 7F Nikken Bldg, 2-1-9 Itachibori, Nishi-ku, Osaka, 550-0012 Japan
TEL : +81 6 6535 4871 FAX : +81 6 6535 4874
E-Mail : eigyou@unikas.co.jp

<http://www.unikas.co.jp>

* Before products operation, read the attached instruction manuals thoroughly the respective supplied instruction manual.
* The contents of this catalog are subject to change without prior notice.

UNIKAS INDUSTRIAL INC.

MHS SERIES

Feather:

MHS Series of Manual Hydraulic Steering System are suitable for both Pleasure Boat and Small Fishing Boat, designed to add safety, reliability and comfort for cruising.

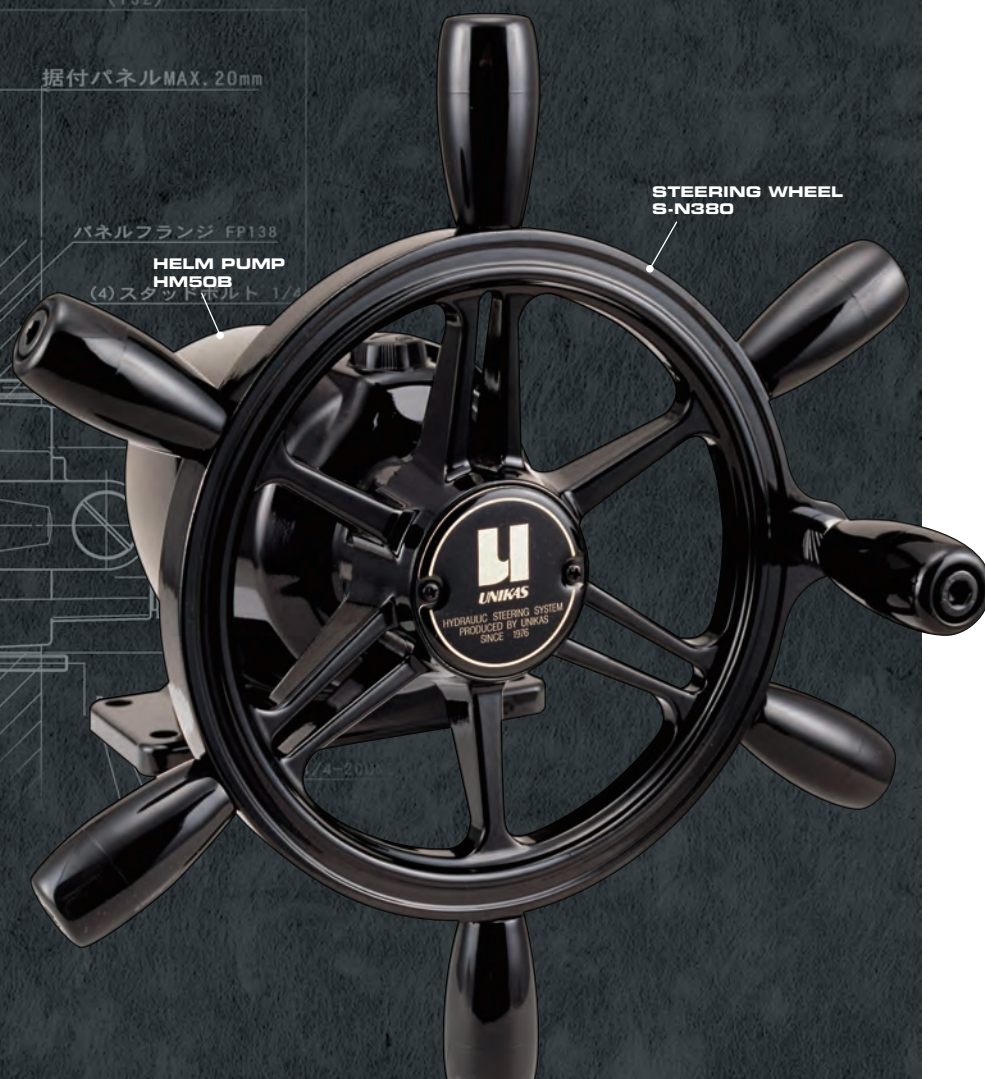

据付パネルMAX. 20mm
パネルフランジ FP138

HELM PUMP



HM50P HM50B

Designed light and compact with the minimum dash panel, and which provides the space can be effectively used in Cabin

There are various displacement and which can be combined with steering cylinders make it possible to correspond to the required specification of various kinds of boats.

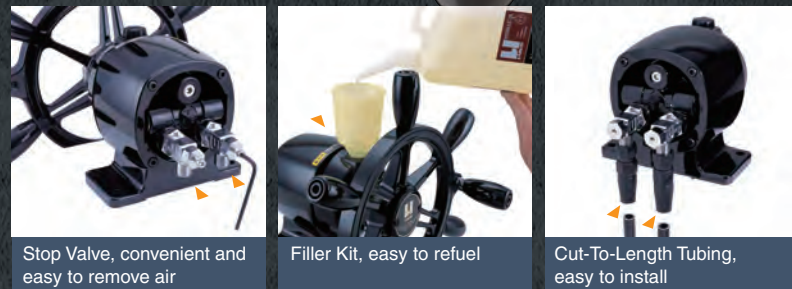

Stop Valve, convenient and easy to remove air

Filler Kit, easy to refuel

Cut-To-Length Tubing, easy to install

Option: Fulfilling optional parts present your active cruising performance.



Complete Kit for 2-control position enhancement



Mounting bracket for HM50

BK-138



Mounting panel kit for HM50

FP-138

Steering Wheel:

Fishing boat type



S-N380

Destroyer type



S-D380

Sport type



S-N340

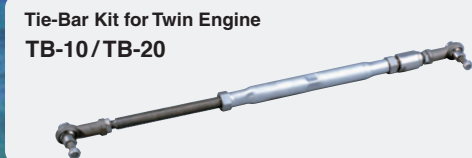

Tie-Bar Kit for Twin Engine TB-10/TB-20

MHS-VX Series



Which are designed for Outboard-Front-Mount-Typed Steering.



Component Kit: MHS-36VX

Specification of MHS-VX Series:

System Model	Max. Torque (N-m)	Wheel Turn lock to lock (rev)	Helm Pump Displacement (cc)	Cylinder	Tubing
MHS-32VXS	659	4.5	HM50 26	32VXS	3/8 HP Hose
MHS-32VX	659	6.9	HM50 20	32VX	3/8 HP Hose
MHS-32VH	659	6.9	HM50 20	32VH	3/8 HP Hose
MHS-36VX	1043	7.3	HM50 23	36VX	3/8 HP Hose

Cylinder Selection Guide:

32VX

Less than 200PS x Single Engine
Less than 150PS x Twin Engines



32VH

Less than 200PS x Single Engine
Less than 150PS x Twin Engines



* Above Applications are different in each type of hull only as a guide

* The mounting hardware & accessories are different in each Engine-Builder and Models

36VX

Less than 300PS x Single Engine
Less than 250PS x Twin Engines



MHS-G/B/UB Series



Component kits come complete with Helm Pump, Steering Cylinder, HP-Hose/Fittings, Hydraulic Oil/Filler Kit and Manual needed for an install in One Packing Case, as showing the picture of Component Kit : MHS-32B



Component Kit: MHS-32B

Speeds up air-removal by utilizing Stop Valve equipped with Helm Pump. Tubing HP hoses are simple to work as to cut length and compress to fittings. The fittings at cylinder are made of stainless steel to add the corrosion resistant.

Specification of MHS-G/B/UB Series:

System Model	Max. Torque (N-m)	Wheel Turn lock to lock (rev)	Helm Pump Displacement (cc)	Cylinder	Tubing
MHS-28G	468	4.9	HM50 20	28G	3/8 HP Hose
MHS-28B	468	4.9	HM50 20	28B	3/8 HP Hose
MHS-32G	668	7.0	HM50 20	32G	3/8 HP Hose
MHS-32B	668	7.0	HM50 20	32B	3/8 HP Hose
MHS-32UB	944	7.7/6.6	HM50 23	32UB	3/8 HP Hose
MHS-40Bi	869	7.8	HM50 23	40Bi	3/8 HP Hose
MHS-L40Bi	1068	9.6	HM50 23	L40Bi	3/8 HP Hose

Application Guide:

28G/32G



32UB



28B/32B

