

■ Outline drawing

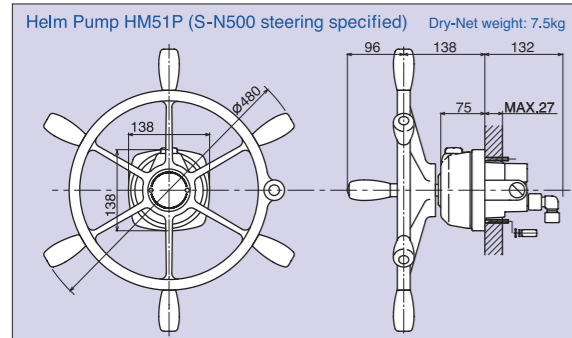

■ Piping diagrams

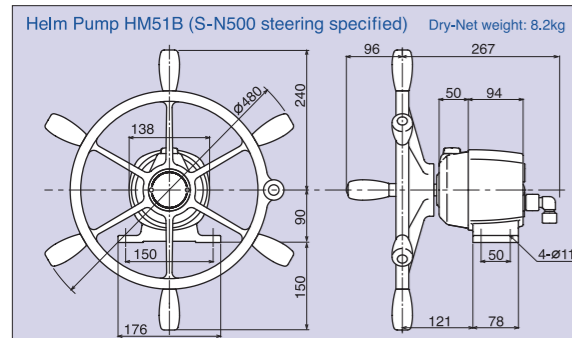
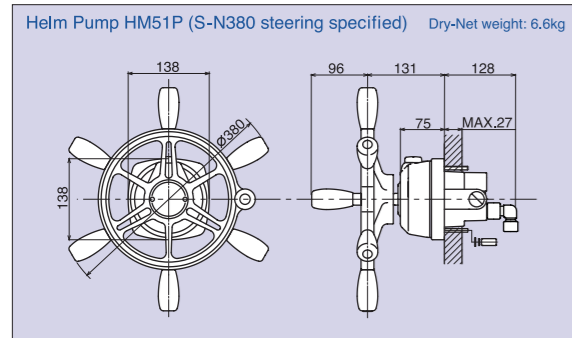
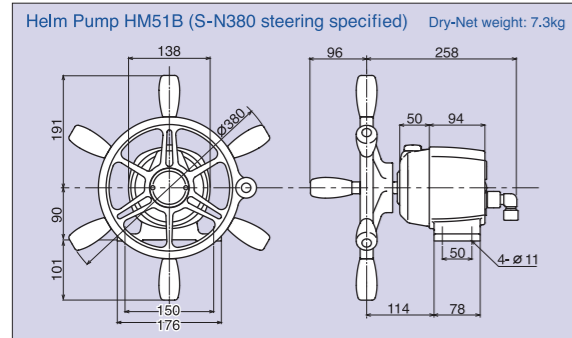
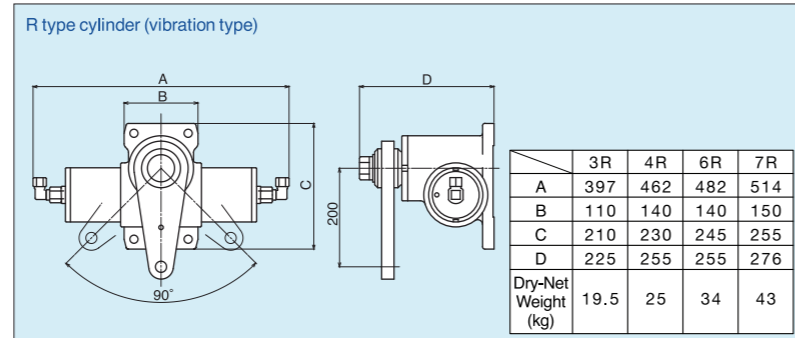
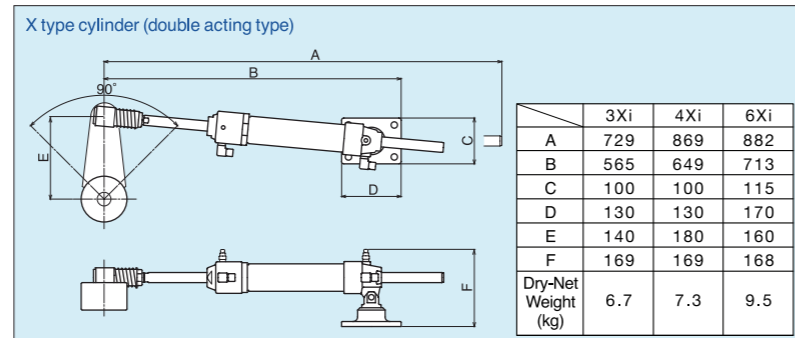
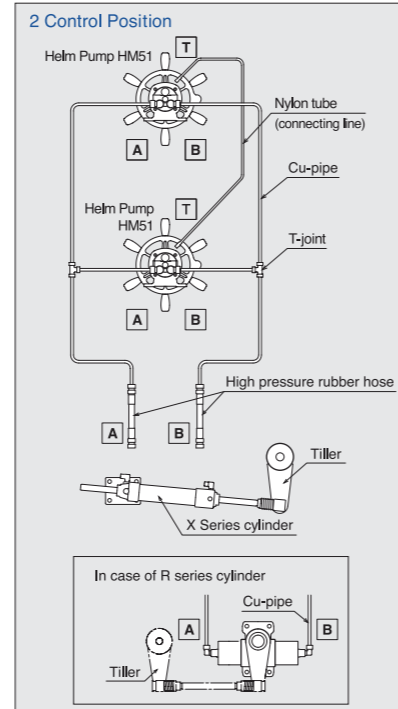
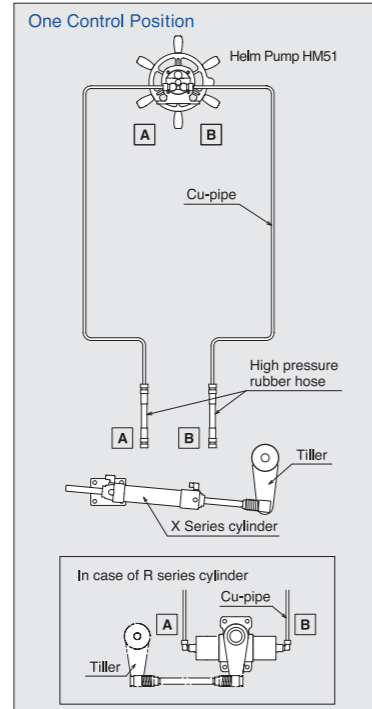

■ System upgrade to Auto Pilot / Steering Remote Controller

Auto Pilot system
CD-50

Dial Remote Controller system
ED-12

DC Power Pack system
(Need to a0-dd Auto Pilot / Dial Remote Controller)

PU040 (24V)
BX-303 (Control Box)

* Before products operation, read the attached instruction manuals thoroughly the respective supplied instruction manual.
* The contents of this catalog are subject to change without prior notice.

UNIKAS INDUSTRIAL INC.

HQ & Factory : 455 Nishibara, Nagi-cho, Katsuta-gun, Okayama, 708-1306 Japan
TEL : +81 (0)868 36 3131 FAX : +81 (0)868 36 6209

Osaka Operation : 7F Nikken Bldg, 2-1-9 Itachibori, Nishi-ku, Osaka, 550-0012 Japan
TEL : +81 6 6535 4871 FAX : +81 6 6535 4874
E-Mail : eigyou@unikas.co.jp

<http://www.unikas.co.jp>

SHD2014.9



HAND HYDRAULIC STEERING SYSTEM

UHS Series

- UHS-3Xi
- UHS-4Xi
- UHS-6Xi
- UHS-3R
- UHS-4R
- UHS-6R
- UHS-7R



UNIKAS INDUSTRIAL INC.

UHS Series

Since its release, it has been a popular basic type of Manual Hydraulic Steering System among the professional fishermen in Japan and world-wide.

To provide high level feeling on operation in all of lineup.

HELM PUMP

HM51P

HM51B

Space can be effectively used in Cabin; Light and compact designed with minimum protrusion from panel.

There are 5 variations of oil discharge and which can be combined with steering cylinders makes it possible to correspond to the required specification of various boats.



Option Fulfilling optional parts present your active fishing performance.

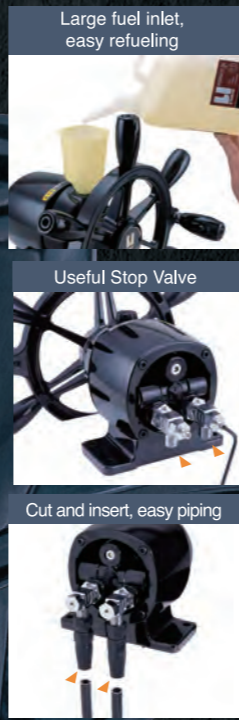
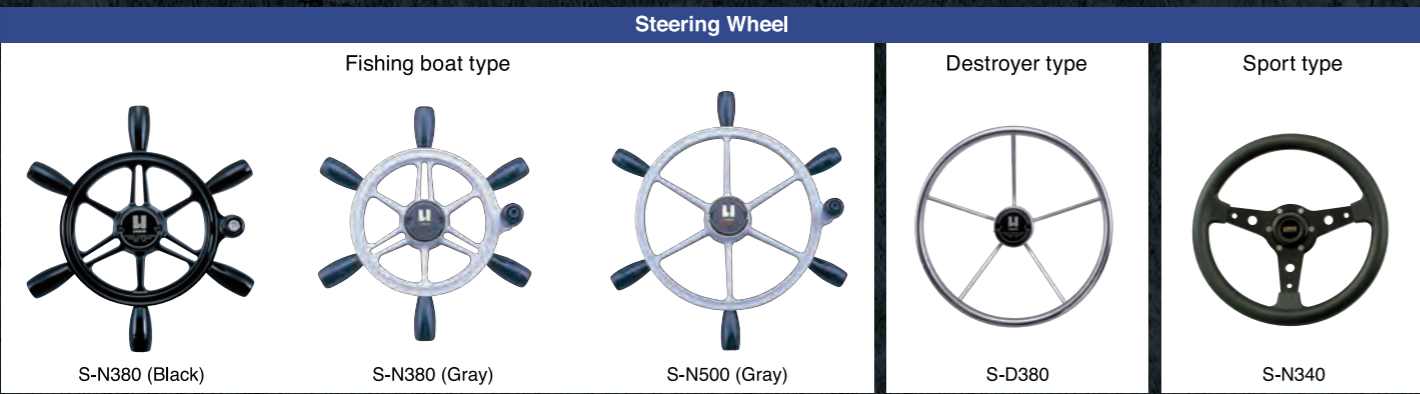

UHS-X Series



Picture shows S-N380 steering (black).

< Popular X-series in fishing-boat-market over the years >

UHS-X series specifications

System Model	Generating Torque (N-m)	Number of Rotations of Steering (turn)	Helm Pump Oil-discharge (cm3)	Steering Cylinder	Piping
UHS-3Xi	1157	7.5	HM51 32	3Xi	Ø12 Cu Pipe
UHS-4Xi	1488	9.6	HM51 32	4Xi	Ø12 Cu Pipe
UHS-6Xi	2059	13.3	HM51 32	6Xi	Ø12 Cu Pipe

Steering cylinder (Double acting type)



UHS-R Series



Picture shows S-N380 steering (gray).

Rotary Actuator has high durability, corrosion resistance and reliability due to Oil Sealed Rack-and-Pinion mechanism, which is a classic type equipped into so many vessels over 30 years in domestic and worldwide. The combination of UHS-R series and new Helm Pump is more effective for steering operation.

UHS-R series specifications

System Model	Generating Torque (N-m)	Number of Rotations of Steering (turn)	Helm Pump Oil-discharge (cm3)	Steering Cylinder	Piping
UHS-3R	830	8.2	HM51 19	10R	Ø12 Cu Pipe
UHS-4R	1473	8.7	HM51 32	15R	Ø12 Cu Pipe
UHS-6R	1892	10.5	HM51 34	20R	Ø12 Cu Pipe
UHS-7R	2386	10.7	HM51 42	25R	Ø12 Cu Pipe

Rotary typed Actuator

